

THE NEW VALUE FRONTIER



Cut-off tool holders for automatic lathe
Available for sub-spindle operations



KTKF-S



Suitable for cut-off with minor clearance between main and sub-spindle

Recommended for small diameter workpieces, or when clearance between main and sub-spindle is small

Compatible with inserts and tool holders of KTKF for small diameter cut-off

Large insert lineup



Cut-off toolholders for automatic lathe: Available for sub-spindle operations

KTKF-S

1 Recommended for cut-off with minor clearance between main and sub-spindle

Thin holder head is applicable when minimal clearance exists between the main spindle and sub spindle

2 For micro diameter and for small diameter available

Compatible with TKF inserts

- TKF12: Max. diameter $\varnothing 5$ mm – $\varnothing 12$ mm
- TKF16: Max. diameter $\varnothing 16$ mm

3 Provide with wide selection of inserts

Available chipbreakers: Right lead angle, S chipbreaker, T chipbreaker, without chipbreaker

Available insert grades: PR1425 for steel machining, PR1535 for stainless steel machining, PDL025 for aluminum machining

KTKF-S type (for sub spindle tooling)

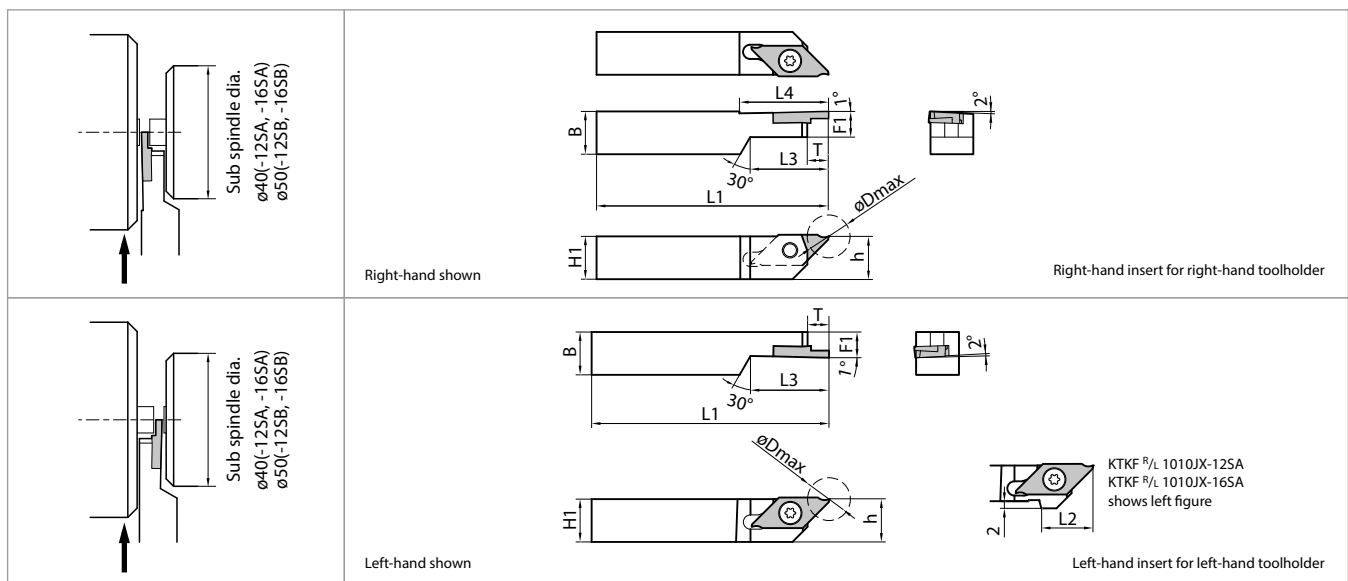

Toolholder dimensions

Description	Availability		Cut-off diameter	Dimension (mm)								Spare parts		Applicable insert		
	R	L		$\varnothing D_{max}$	H1 = h	B	L1	L2	L3	*L4	F1	T	Clamp screw		Wrench	
KTKF R/L 1010JX-12SA	●	●	5 – 12	10	10	120	15	22	26	7.2	6	SB-4570TRN	LTW-10S	TKF12 R/L		
KTKF R/L 1212F-12SA	●	●		12	12	85	–									
KTKF R/L 1212JX-12SB	●	●		120	–	26										
KTKF R/L 1010JX-16SA	●	●	16	10	10	120	20	22	30	7.2	8			SB-4570TRN	LTW-10S	TKF16 R/L
KTKF R/L 1212F-16SA	●	●		12	12	85	–									
KTKF R/L 1212JX-16SB	●	●		120	–	26										











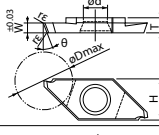

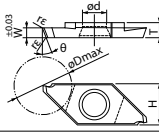

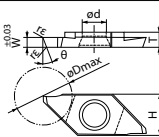
• Dimension T shows the distance from the toolholder to the cutting edge

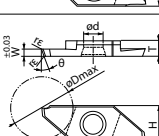
• Cut-off diameter ($\varnothing D_{max}$) depends on the insert edge width

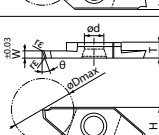
* Only Right-hand is available for L4 dimension

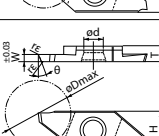
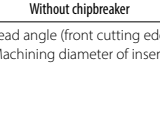
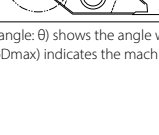
● : Available

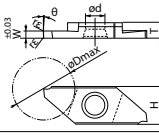
Applicable insert (TKF12/TKF16)

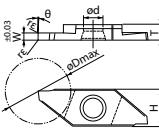
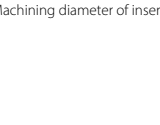
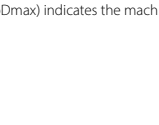
Shape Right-hand insert shown		Description	Dimension (mm)						Angle θ	MEGACOAT NANO		MEGACOAT		PVD coated carbide		DLC coated carbide		Carbide							
			W	φDmax	rε	T	H	φd		PR1425	PR1535	PR1225	PR1025	PDL025	KW10										
 Right lead angle		TKF12R/L 050-S-16DR	0.5	5	0.03	3	8.7	5	16°	●	●	●	●	●	●	●	●	●	●						
		TKF12R/L 070-S-16DR	0.7	8						●	●	●	●	●	●	●	●	●	●	●	●	●	●		
		TKF12R/L 100-S-16DR	1.0	12						●	●	●	●	●	●	●	●	●	●	●	●	●	●		
		TKF12R/L 125-S-16DR	1.25	12						●	●	●	●	●	●	●	●	●	●	●	●	●	●		
		TKF12R/L 150-S-16DR	1.5	12						●	●	●	●	●	●	●	●	●	●	●	●	●	●		
 Right lead angle / Tough edge		TKF12R/L 100-T-16DR	1.0	12	0.08	3	8.7	5	16°	●	●	●	●	●	●	●	●	●	●						
		TKF12R/L 150-T-16DR	1.5							●	●	●	●	●	●	●	●	●	●	●	●	●	●		
		TKF12R/L 200-T-16DR	2.0							●	●	●	●	●	●	●	●	●	●	●	●	●	●	●	
		TKF12R/L 100-T	1.0							12	0.08	3	8.7	5	0°	●	●	●	●	●	●	●	●	●	●
		TKF12R/L 150-T	1.5													●	●	●	●	●	●	●	●	●	●
TKF12R/L 200-T	2.0	●	●	●	●	●	●	●	●							●	●	●	●	●	●				
 Right lead angle without chipbreaker		TKF12R/L 050-NB-20DR	0.5	5	0	3	8.7	5	20°	●	●	●	●	●	●	●	●	●	●						
		TKF12R/L 070-NB-20DR	0.7	8						●	●	●	●	●	●	●	●	●	●	●	●	●			
		TKF12R/L 100-NB-20DR	1.0	12						●	●	●	●	●	●	●	●	●	●	●	●	●			
		TKF12R/L 150-NB-20DR	1.5	12						●	●	●	●	●	●	●	●	●	●	●	●	●			
		TKF12R/L 200-NB-20DR	2.0	12						●	●	●	●	●	●	●	●	●	●	●	●	●	●		
 Without chipbreaker		TKF12R/L 050-NB	0.5	5	0	3	8.7	5	0°	●	●	●	●	●	●	●	●	●	●						
		TKF12R/L 070-NB	0.7	8						●	●	●	●	●	●	●	●	●	●	●	●	●			
		TKF12R/L 100-NB	1.0	12						●	●	●	●	●	●	●	●	●	●	●	●	●			
		TKF12R/L 150-NB	1.5	12						●	●	●	●	●	●	●	●	●	●	●	●	●			
		TKF12R/L 200-NB	2.0	12						●	●	●	●	●	●	●	●	●	●	●	●	●	●		
 Right lead angle		TKF16R/L 150-S-16DR	1.5	16	0.05	4	9.5	5	16°	●	●	●	●	●	●	●	●	●	●						
		TKF16R/L 200-S-16DR	2.0							●	●	●	●	●	●	●	●	●	●	●	●	●	●	●	
 Right lead angle / Tough edge		TKF16R/L 150-S	1.5	16	0.05	4	9.5	5	0°	●	●	●	●	●	●	●	●	●	●						
		TKF16R/L 200-S	2.0							●	●	●	●	●	●	●	●	●	●	●	●	●	●	●	
 Tough edge		TKF16R/L 150-T-16DR	1.5	16	0.08	4	9.5	5	16°	●	●	●	●	●	●	●	●	●	●						
		TKF16R/L 200-T-16DR	2.0							●	●	●	●	●	●	●	●	●	●	●	●	●	●	●	
 Tough edge		TKF16R/L 150-T	1.5	16	0.08	4	9.5	5	0°	●	●	●	●	●	●	●	●	●	●						
		TKF16R/L 200-T	2.0							●	●	●	●	●	●	●	●	●	●	●	●	●	●	●	
 Right lead angle without chipbreaker		TKF16R/L 150-NB-20DR	1.5	16	0	4	9.5	5	20°	●	●	●	●	●	●	●	●	●	●						
		TKF16R/L 200-NB-20DR	2.0							●	●	●	●	●	●	●	●	●	●	●	●	●	●	●	
 Without chipbreaker		TKF16R/L 150-NB	1.5	16	0	4	9.5	5	0°	●	●	●	●	●	●	●	●	●	●						
		TKF16R/L 200-NB	2.0							●	●	●	●	●	●	●	●	●	●	●	●	●	●	●	

Lead angle (front cutting edge angle: θ) shows the angle when installed in the toolholder

Machining diameter of insert (φDmax) indicates the machining diameter when the tool tip has proceeded to the center of workpiece as in Fig. 1 on next page

● : Available

Insert description

TKF 12 R 050 – S – 16D R

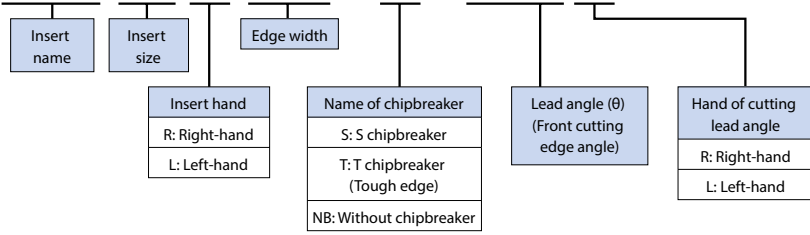

Holder	Right-hand (R)	Holder	Left-hand (L)
Insert	Right-hand (R)	Insert	Left-hand (L)
Lead angle	Right-hand (R)	Lead angle	Right-hand (R)
Toolholder hand : R		Toolholder hand : L	

Table 1

Cut-off diameter of the insert (øDmax)

When using main spindle only

Workpiece maximum øD1 (Fig.1) = øDmax
 Even if the cutting edge runs beyond the center line, the insert does not contact the workpiece, since the workpiece falls off. The clearance between the insert and the workpiece is 0.2 mm

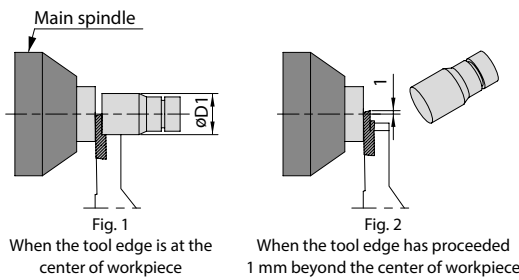

When using both main and sub spindles

In this case, when the cutting edge runs beyond the center line, the insert will contact the workpiece, since the workpiece does not fall off. Therefore the programmed distance beyond the center must be considered.

Example: When the cutting edge is programmed to run 1 mm beyond the center of workpiece (Fig. 4), the maximum machining diameter of workpiece on cut-off side. øD2 (Fig. 4) = [øDmax – 1 mm × 2] (mm). The clearance between the insert and the workpiece is 0.2 mm

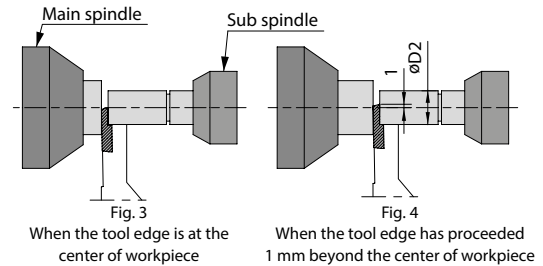

Recommended cutting conditions ★ 1st recommendation ☆ 2nd recommendation

Workpiece	Recommended insert grade (Vc: m/min)						TKF12						TKF16		Notes
							Edge width W (mm)						Edge width W (mm)		
	MEGACOAT NANO		MEGACOAT	PVD coated carbide	DLC coated carbide	Carbide	0.5	0.7	1.0	1.25	1.5	2.0	1.5	2.0	
	PR1425	PR1535	PR1225	PR1025	PDL025	KW10	f (mm/rev)						f (mm/rev)		
Carbon steel	★ 70 – 170 (50 – 140)	☆ 70 – 150 (50 – 120)	☆ 70 – 150 (50 – 120)	☆ 60 – 130	–	–	0.01 – 0.02	0.01 – 0.03	0.01 – 0.04 (0.01 – 0.05)	0.01 – 0.04	0.01 – 0.04 (0.02 – 0.1)	0.01 – 0.04 (0.02 – 0.1)	0.02 – 0.07 (0.02 – 0.1)	0.02 – 0.07 (0.02 – 0.1)	
Alloy steel	★ 70 – 170 (50 – 140)	☆ 70 – 150 (50 – 120)	☆ 70 – 150 (50 – 120)	☆ 60 – 130	–	–	0.01 – 0.02	0.01 – 0.03	0.01 – 0.04 (0.01 – 0.05)	0.01 – 0.04	0.01 – 0.04 (0.02 – 0.1)	0.01 – 0.04 (0.02 – 0.1)	0.02 – 0.07 (0.02 – 0.1)	0.02 – 0.07 (0.02 – 0.1)	
Stainless steel	☆ 60 – 140 (40 – 120)	★ 60 – 120 (40 – 100)	☆ 60 – 120 (40 – 100)	☆ 50 – 100	–	–	0.005 – 0.015	0.01 – 0.02	0.01 – 0.02 (0.01 – 0.03)	0.01 – 0.02	0.01 – 0.02 (0.01 – 0.05)	0.01 – 0.02 (0.01 – 0.05)	0.01 – 0.04 (0.01 – 0.05)	0.01 – 0.04 (0.01 – 0.05)	
Cast iron	–	–	–	–	–	★ 50 – 100	0.01 – 0.03	0.01 – 0.04	0.01 – 0.05	0.01 – 0.05	0.01 – 0.05	0.01 – 0.05	0.02 – 0.08	0.02 – 0.08	
Aluminum alloys	–	–	–	–	★ 200 – 500	☆ 200 – 450	0.01 – 0.03	0.01 – 0.04	0.01 – 0.05	0.01 – 0.05	0.01 – 0.05	0.01 – 0.05	0.02 – 0.08	0.02 – 0.08	
Brass	–	–	–	–	–	★ 100 – 200	0.01 – 0.03	0.01 – 0.04	0.01 – 0.06	0.01 – 0.06	0.01 – 0.06	0.01 – 0.06	0.02 – 0.1	0.02 – 0.1	

Recommendations in parentheses (): Tough edge type (TKF.T.)